

To be the best Powertrain maker in the world 

(株)DIC  
会社紹介書

2020.02



# 目次

1. 企業概要

2. DICの歩み

3. 売上現況

4. 生産拠点

5. 主な生産品

6. 主な取引先

7. 主な設備現況

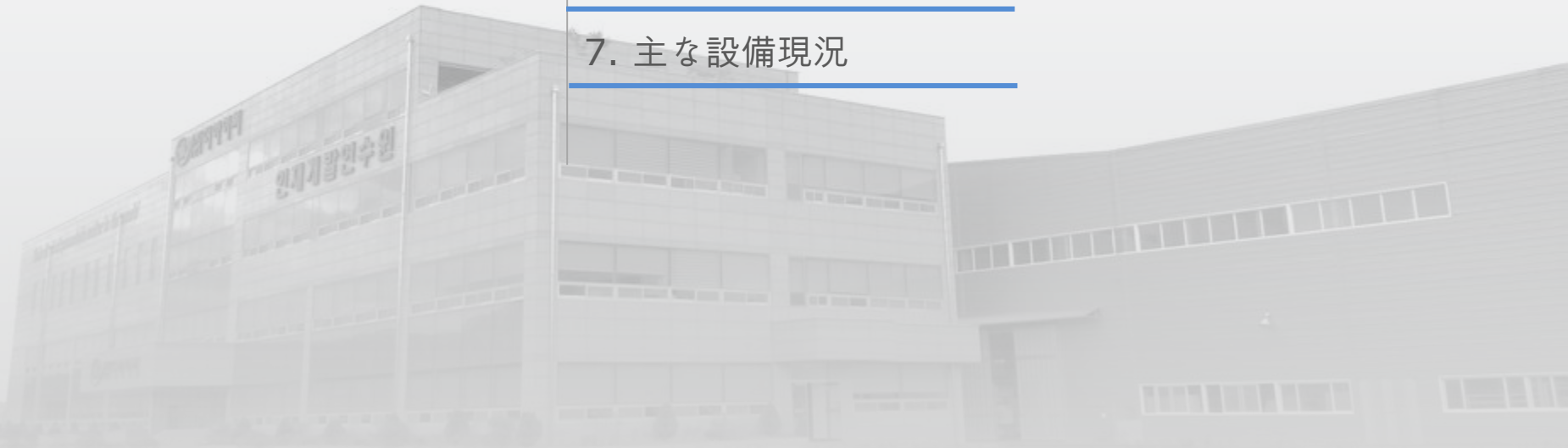

■ 会社名	株式会社DIC
■ 代表者	金正烈
■ 設立日	1976年 8月 3日
■ 業 種	自動車用動力伝達装置製造業
■ 所在地	8, Bonggyenoggonggil, Dudong-myoen, Ulju-gun, Ulsan, Korea
■ 売上高	377億円(単独)、589億円(連結)
■ 従業員	760名(単独)、1,545名(連結)
■ 主な製品	自動車用T/M及びエンジン部品 産業車輛用T/M及びDrive Axle

## 創業段階 1976年~1989年

農機械用動力伝達装置開発  
組立生産体制構築



- '76. **大一工業(株)設立**
- '80. PUMP用Gear類最初輸出  
自動車及びMotorcycle用  
変速機ギヤ輸出
- '86. 農機械用Transmission,  
Front Axle Ass'y 生産
- '89. 彦陽工場竣工

## 市場進入段階 1990年~1999年

自動車部品市場進入  
産業車輛(Forklift)変速機の独自開発



- '90. Forklift用 T/M 生産  
自動車用 T/M 生産
- '91. 大湖機械工業(株)竣工
- '96. **斗東工場竣工**  
**変速機技術研究所設立**
- '97. M5EF1(軽型) I/P, O/P  
Diff Ass'y 3種開発
- '98. ISO 9002 認証獲得

## グローバル進入段階 2000年~2010年

中国現地進出  
MotorcycleのPowertrain部品販売



- '01. QS 2000 認証獲得
- '04. **中国現地法人設立**  
**(大一汽配有限公司)**
- '06. **株式会社 DICに社名変更**
- '07. **証券取引所上場**  
**1億ドル輸出塔受賞**
- '08. 6速 A/T Sun GR,  
O/D HUB, R/SFT 開発
- '10. 北米GM 6速 A/T  
Output Hub 開発

## 2011年~現在

DCT及び減速機等の核心部品開発  
VISION 2020 推進(売上 1兆 達成)



- '11. 韓国形Hidden Champion  
選定(輸出入銀行)
- '14. 7DCT用 Gear, shaft,  
Sync-Sleeve 開発
- '16. **7DCT用 Diff Ass'y 開発**  
**GM 電気車減速機部品開発**  
**a社 減速機Shaft及びGear**  
開発  
**LG電気車減速機部品開発**
- '18. **アメリカケンタッキー州北**  
**米工場着工**  
(鍛造及びギヤ加工、組立)

## 2019年売上実績

## 2020年売上計画

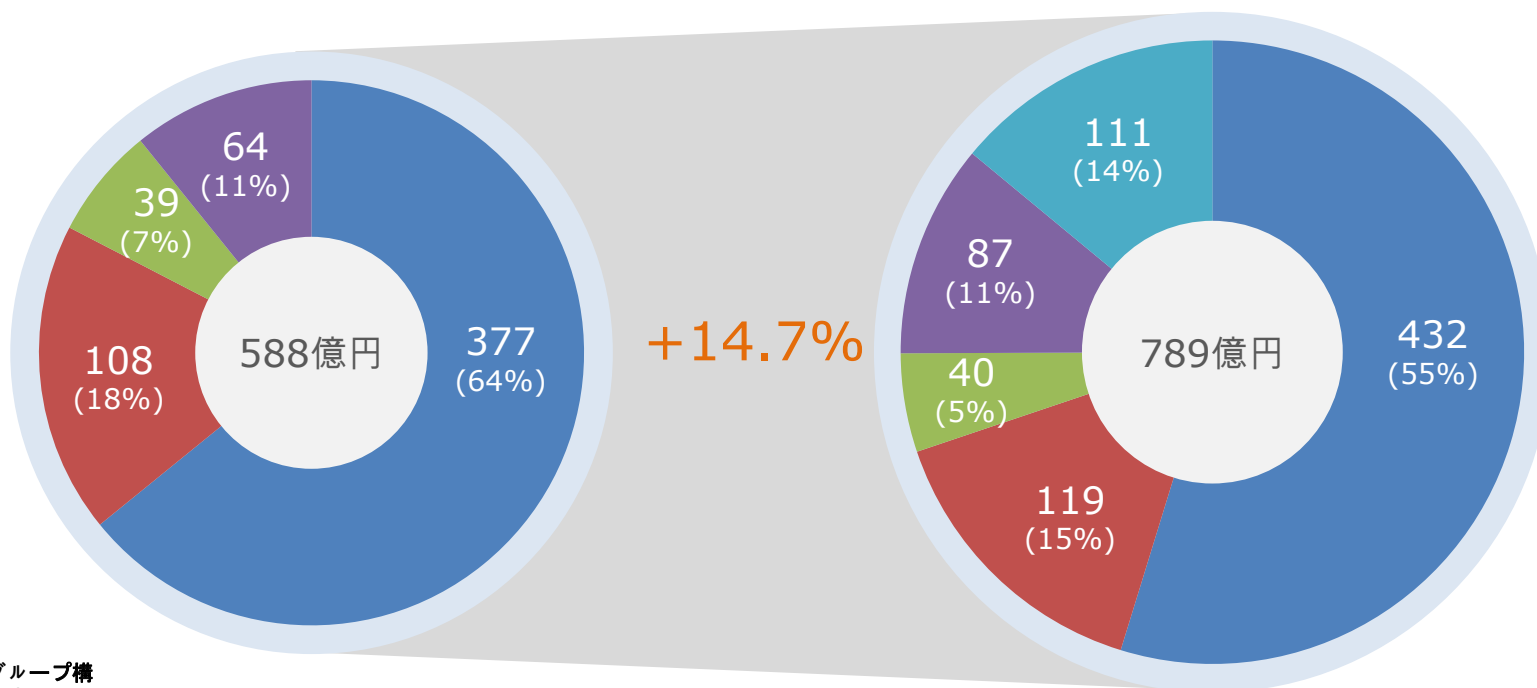

### DIC グループ構造

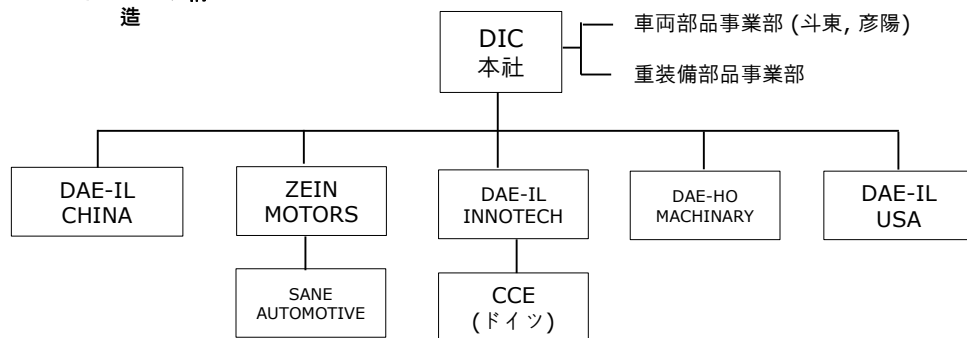

- DIC
- DAE-IL INNOTECH
- DAE-HO MACHINERY
- DAE-IL CHINA(中国)
- ZEINMOTORS

# 4. 生産拠点

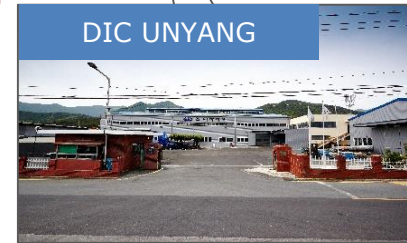

# 5-1. MANUAL T/M PARTS

H社



K社



RT-10



M5ZR1



M6AR1



REV. IDLER GEAR



INPUT SHAFT SUB ASS'Y



OUTPUT SHAFT SUB ASS'Y

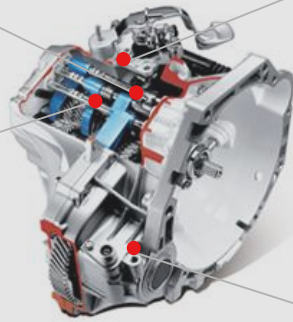

M5EF2



DIFF SUB ASS'Y

H社



K社



# 5-2. DCT & A/T PARTS

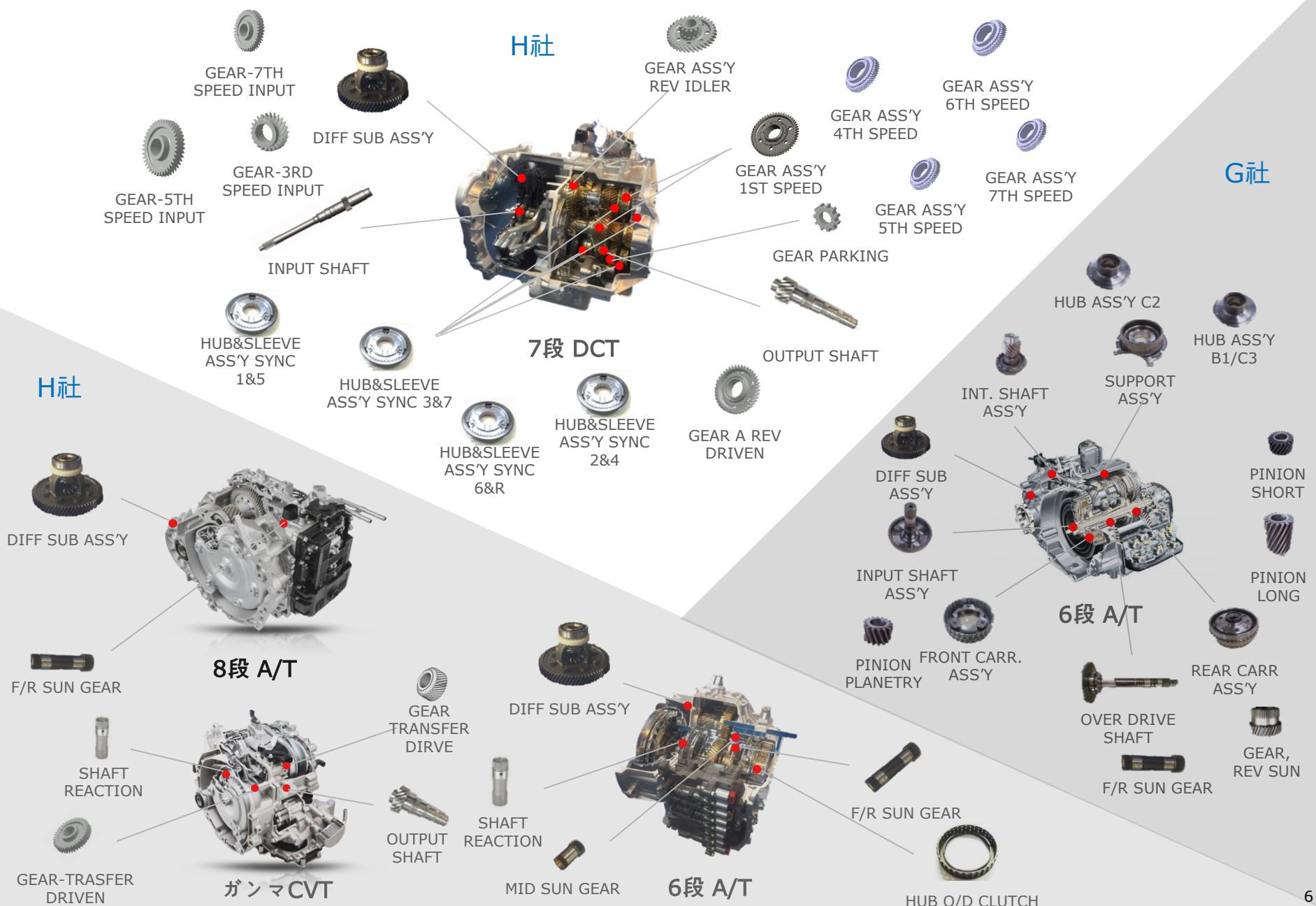



## Diff Gear 年間生産数量



T5, M200  
(160万個/年)

UK

Jaguar Land Rover  
Range Rover



T6 2018  
(120万個/年)

TH

Ford Ranger



M60, P558  
(180万個/年)

US  
MX

FORD F250



M5EF2  
(40万個/年)

KR

HYUNDAI/KIA  
Picanto



M230  
(3万個/年)

S.A

Toyota Hilux



G社

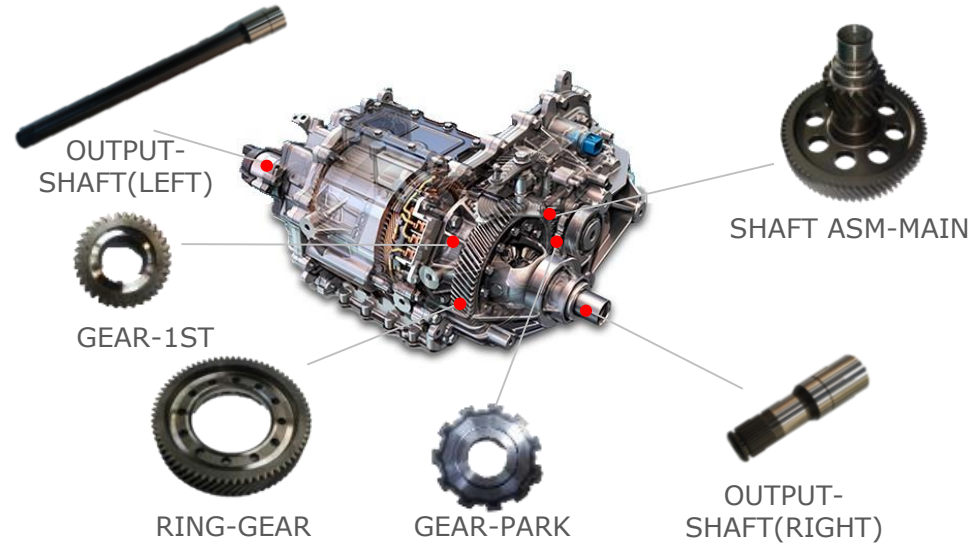

a社



# 5-5. 電氣車減速機

To be the best Powertrain maker in the world

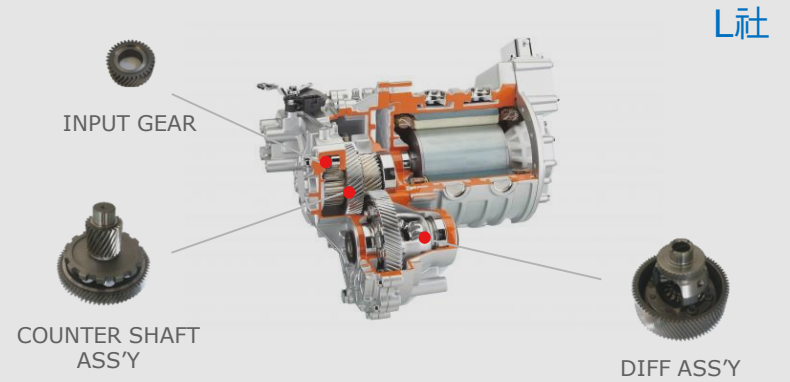

D社



## DRIVE AXLE



## TRANSMISSION



## TRANS AXLE



## PARTS FOR MOTORCYCLE



## Wheeled Exvator



30Ton

22Ton



## Swing Device

### 1. 車両部品事業部



HMC



KMC



現代TRANSYS



現代WIA



GMK



現代GLOVIS



現代MOBIS



LG電子

### 2. 重装備部品事業部



DOOSAN INFRACORE



CLARK



HHI

## 1. 北米

---



DANA



GM



POLARIS



MCFA

## 2. アジア

---



LOGISNEXT



DAISO  
CHEMICAL

DAISO CHEMICAL



TSUBAKIMOTO



GEELY

GEELY

# 7. 主な設備現況

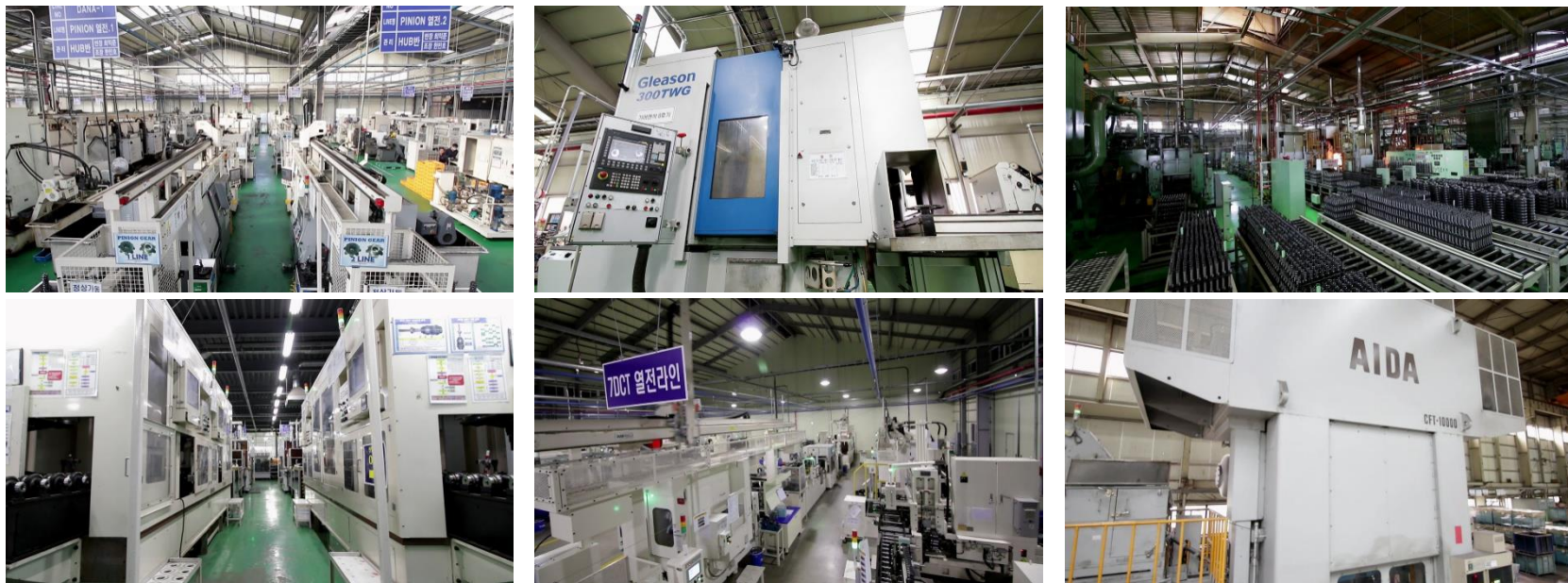

NO	区分	設備種類	台数
1	一般切削設備	CNC旋盤, CNC Milling, MCT等	611
2	ギヤ加工設備	HOB M/C, Shaving M/C, Gear Saper M/C, Broach M/C等	321
3	<b>研磨設備</b>	<b>ギヤ研磨機, 内径/外径研磨機等</b>	<b>483</b>
4	熱処理設備	浸炭熱処理炉(連続炉/バッチ炉), Tempering炉, 高周波熱処理炉, 軟質化炉等	45
5	測定設備	3次元測定機, 形状測定機, ギヤ測定機, 硬度測定機, 金属分析機, 粗さ及び円筒度測定機等	288
6	<b>冷間鍛造設備</b>	2,500 ton (250万個/年), 1,250 ton (380万個/年), 1,000 ton (700万個/年), 630 ton (250万個/年), 650 ton	6
<b>TOTAL</b>			<b>1,754</b>